



YSR315G211



1. SCOPE

This specification shall cover the characteristics of 1-port SAW resonator with YSR315G211 used for remote-control security.

2. ELECTRICAL SPECIFICATION

2.1 Maximum Rating

DC Voltage VDC	10V
AC Voltage Vpp	10V 50Hz/60Hz
Operation temperature	-40°C to +85 °C
Storage temperature	-45°C to +85 °C
Max Input Power	10 dBm

2.2 Electronic Characteristics

Item	Unites	Minimum	Typical	Maximum
Center Frequency	MHz	314.900	315.000	315.100
Insertion Loss	dB		1.4	2.2
Quality Factor	Unload Q	8000	12800	
	50 Ω Loaded Q	1000	2000	
Temperature Stability	Turnover Temperature	°C	10	25
	Freq.temp.Coefficient	ppm/°C ²		0.032
Frequency Aging	ppm/yr		< ±10	
DC. Insulation Resistance	MΩ	1.0		
Transducer Static Capacitance C0	pF		2.13	

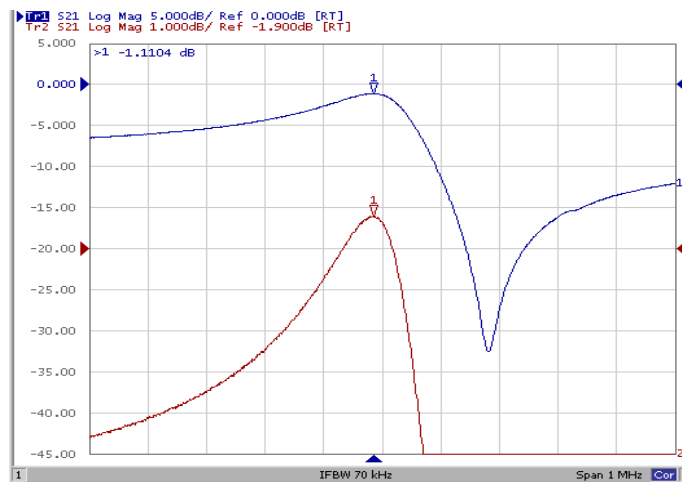



YSR315G211



3. TEST CIRCUIT

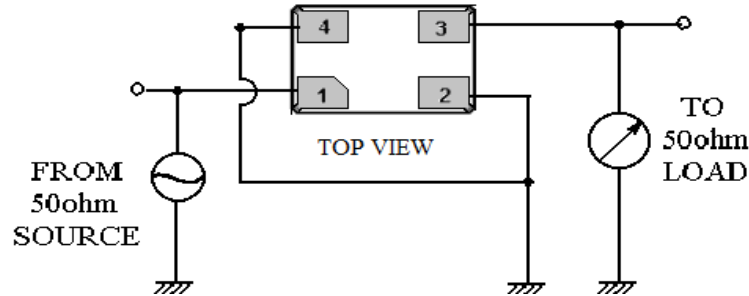

4. DIMENSION

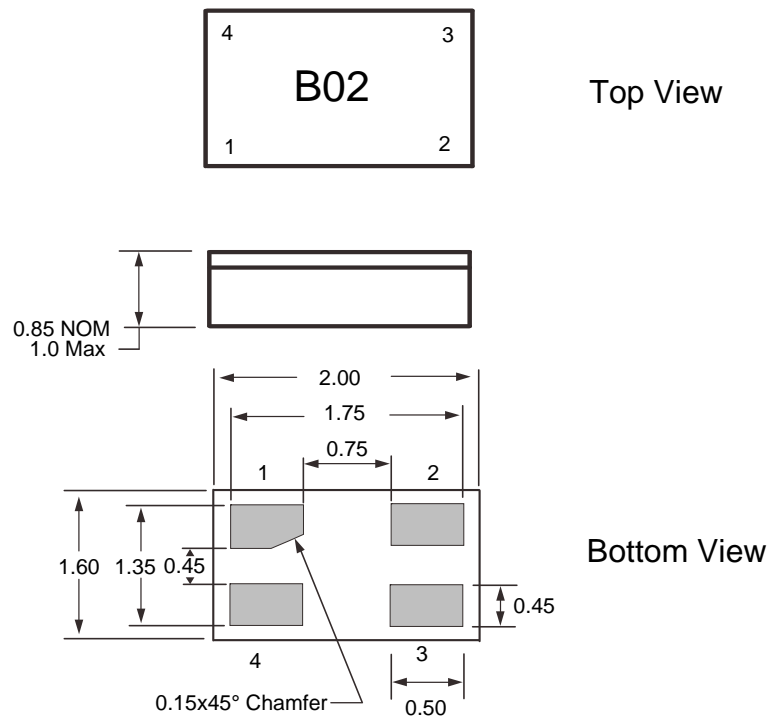

Pin Configuration

- 1. Input / Output
- 3. Output / Input
- 2,4. Ground

5. ENVIRONMENTAL CHARACTERISTICS

5-1 High temperature exposure

Subject the device to +85°C for 16 hours. Then release the filter into the room conditions for 24 hours prior to the measurement. It shall fulfill the specifications in 2-2.



YSR315G211



5-2 Low temperature exposure

Subject the device to -40°C for 16 hours. Then release the device into the room conditions for 24 hours prior to the measurement. It shall fulfill the specifications in 2-2.

5-3 Temperature cycling

Subject the device to a low temperature of -40°C for 30 minutes. Following by a high temperature of $+85^{\circ}\text{C}$ for 30 Minutes. Then release the device into the room conditions for 24 hours prior to the measurement. It shall meet the specifications in 2-2.

5-4 Resistance to solder heat

Dip the device terminals no closer than 1.5mm into the solder bath at $260^{\circ}\text{C} \pm 10^{\circ}\text{C}$ for 10 ± 1 sec. Then release the device into the room conditions for 4 hours. The device shall meet the specifications in 2-2.

5-5 Solderability

Subject the device terminals into the solder bath at $245^{\circ}\text{C} \pm 5^{\circ}\text{C}$ for 5s. More than 95% area of the terminals must be covered with new solder. It shall meet the specifications in 2-2.

5-6 Mechanical shock

Drop the device randomly onto the concrete floor from the height of 1m 3 times. the device shall fulfill the specifications in 2-2.

5-7 Vibration

Subject the device to the vibration for 1 hour each in x, y and z axes with the the amplitude of 1.5 mm at 10 to 55Hz. The device shall fulfill the specifications in 2-2.

6. REMARK

6.1 Static voltage

Static voltage between signal load & ground may cause deterioration & destruction of the component. Please avoid static voltage.

6.2 Ultrasonic cleaning

Ultrasonic vibration may cause deterioration & destruction of the component. Please avoid ultrasonic cleaning

6.3 Soldering

Only leads of component may be soldered. Please avoid soldering another part of component.

7. PACKING

7.1 Dimensions

- (1) Carrier Tape: Figure 1
- (2) Reel: Figure 2
- (3) The product shall be packed properly not to be damaged during transportation and storage.

7.2 Reeling Quantity

1000 pcs/reel 7"



YSR315G211



7.3 Taping Structure

(1) The tape shall be wound around the reel in the direction shown below.

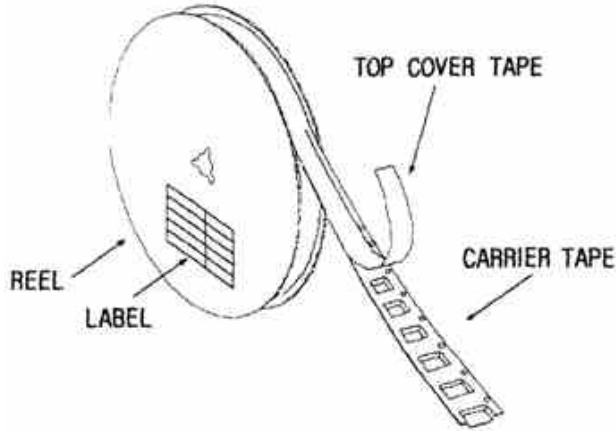

(2) Label

Device Name	
User Product Name	
Quantity	
Lot No.	

(3) Leader Part and vacant position specifications.

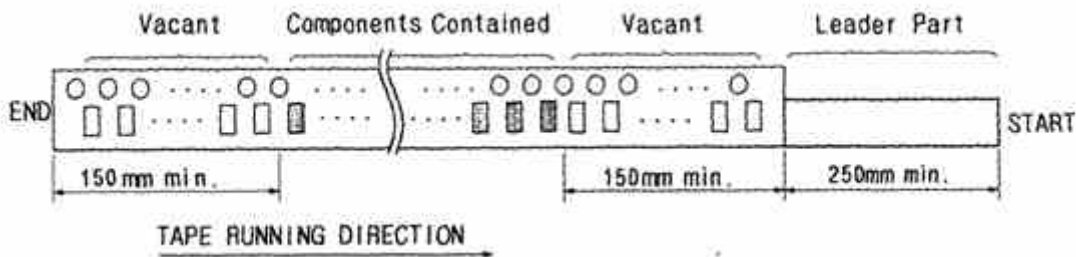

8. TAPE SPECIFICATIONS

8.1 Tensile Strength of Carrier Tape: 4.4N/mm width

8.2 Top Cover Tape Adhesion (see the below figure)

- (1) pull off angle: 0~15°
- (2) speed: 300mm/min.
- (3) force: 20~70g

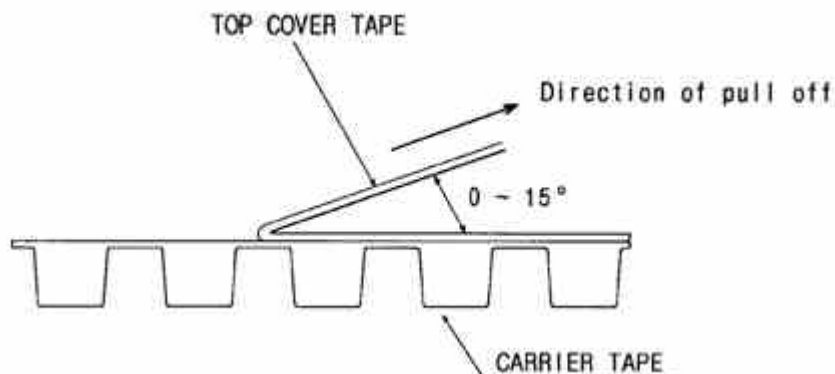



YSR315G211



[Figure 1] Carrier Tape Dimensions

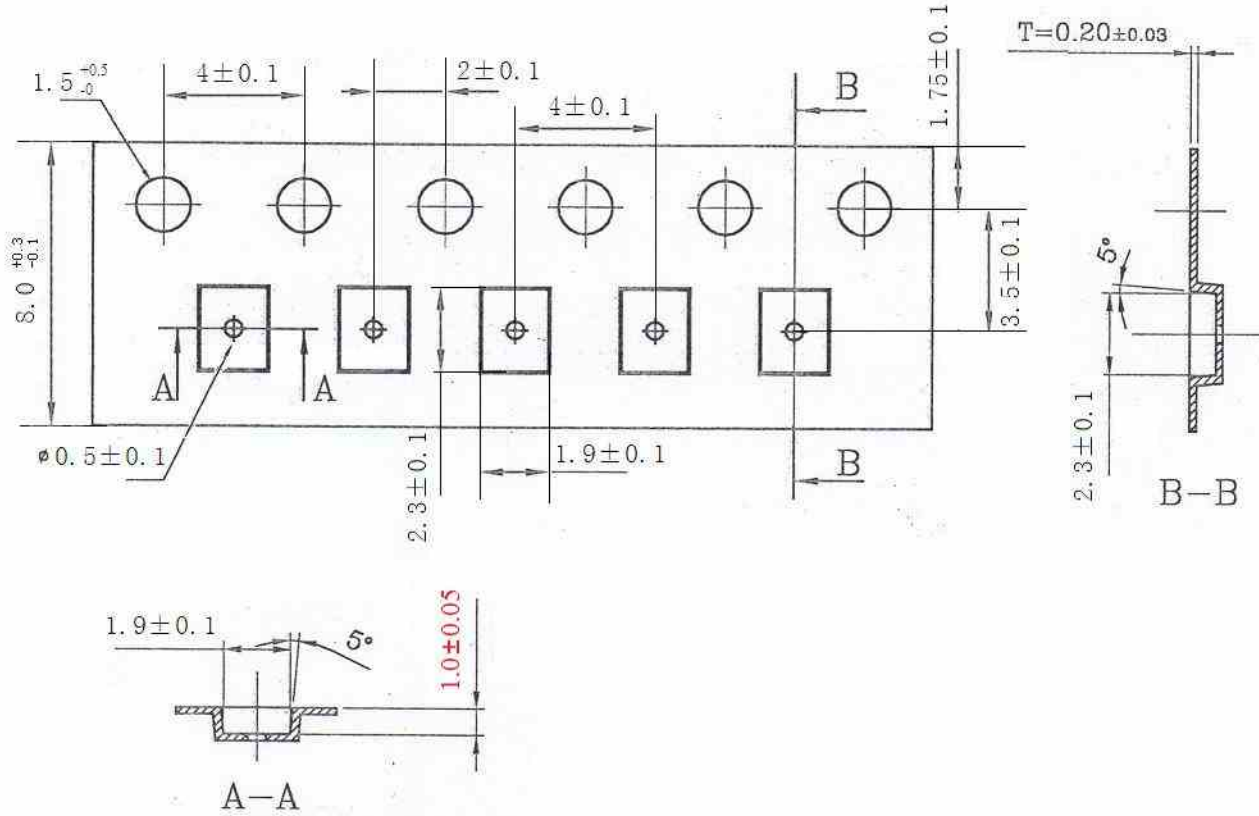

[Figure 2] 10000 pcs/reel

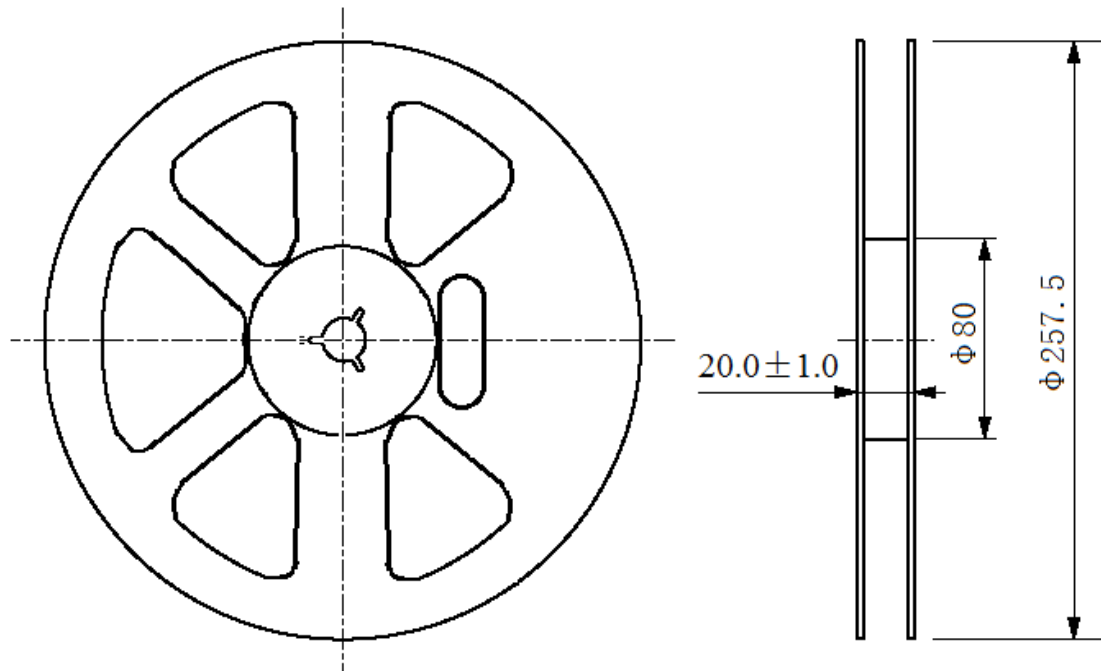

$\phi 257.5$ Reel Dimension

(in mm)